

CHANGING LINEAR BEARINGS SAVES \$100,000 ANNUALLY IN RAW MATERIALS AND ELIMINATES DOWNTIME

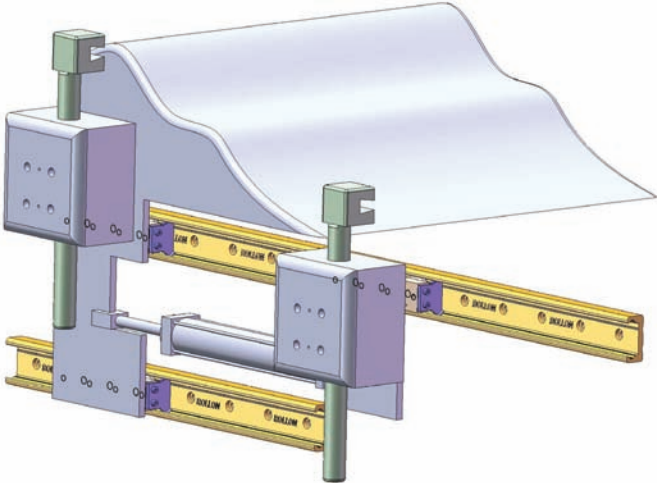

A manufacturer of ready-to-mount automotive carpeting discovered that for every inch that they can stretch the carpet; the plant could save \$100,000 per year in raw materials costs. Therefore the linear motion system used to mount the carpeting not only needs to be strong enough to achieve this target, but it also needs to be able to function on a continuous basis.

The manufacturer in questions has 50 molds, each of which requires a three man crew to work in dual shift operations for seven days a week. Each mold has a pad set into it and the top layer of carpeting is manually laid over the mold so that a linear system, containing bearings and a carpet-tack filled pneumatic actuator, can grab and then stretch the carpet. At \$100,000 per extra inch of material saved, the role of the linear system is critical.

The problem with such an aggressive system is that the profiled slider rails would only last about three months and would therefore require regular changing. On top of the expense of replacing the equipment, the standard interval for changing was about two weeks so production was severely halted.

ROLLON, a leading provider of linear motion systems, had its technical sales team evaluate the system and found the root of the problem. The high cantilever and contamination were the two main reasons for failure. Carpet fibers were finding their way into the re-circulating ball tracks and plugging them up. The facility was spending an average of \$104,000 every year in replacement costs.

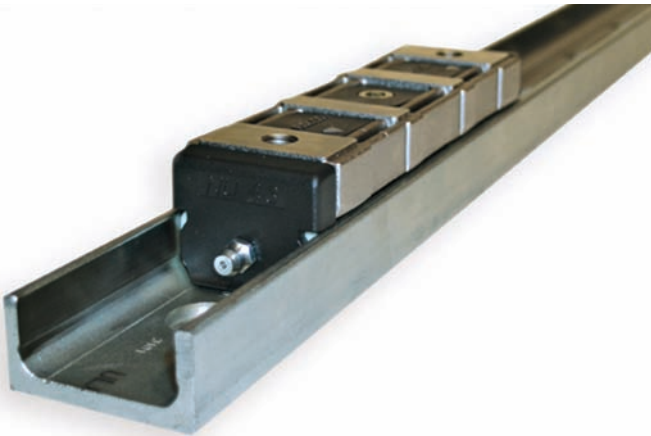

ROLLON specified its Compact Rail linear bearing system, which has raceways on the inside of the rails to protect them from damage and contaminants while enabling the rail and slider to be mounted into small, compact, areas.

Built-in, spring-loaded wipers in the heads and the lateral seals on the sides of the slider ensure they are suitable for the dirtiest of environments. These 'Lubed for Life' wipers continually deposit a thin film of oil on the races. Individual sliders can carry up to 3300 lbs. and can move up to 9 m/s.

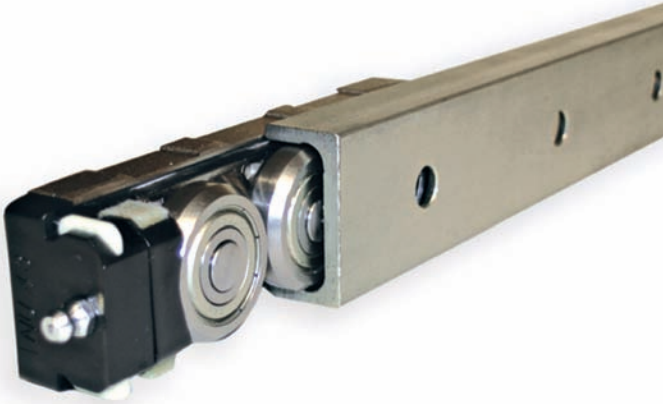

Compact Rail also absorbs rotational positioning errors, misalignments between lateral planes, longitudinal parallelism errors, or a combination of all of these while still maintaining the system's original preload setting. It is designed to provide smooth movement whether mounting plane parallelism can be guaranteed or not.

The Compact Rail system was installed in November 2004 and today they are still running without any need for replacement. The manufacturer has not only seen increased productivity due to no downtime, but has also saved \$104,000 per year in replacement part costs.

For more information visit www.rollonnews.com.